

# **KL-650 Automatic Gluing Machine**

# **KL-650 Paper Pasting Machine**

# **KL-650 Book Cover Machine**

## **ZHEJIANG KANGLI PLASTIC-COATING MACHINE CO.**

The Chinese supplier and manufacturer of Casemaker, Gluing Laminator Machine, Box making machine,-Cardboard Slotting Machine, Creasing & Cutting Machine, Surface Binding Machine. We also manufacture various PVC packages, rosewood and redwood boxes, and cartons.

Address: 104 National Highway, Side of Pingyang Toll Station, Zhejiang ,China

Telephone: 0086-13695835483      0086 -577-63016333

Fax: 0086-577-63017420

E-mail: [admin@kanglycn-packing.com](mailto:admin@kanglycn-packing.com)

Website: <http://www.kanglycn-packing.com>

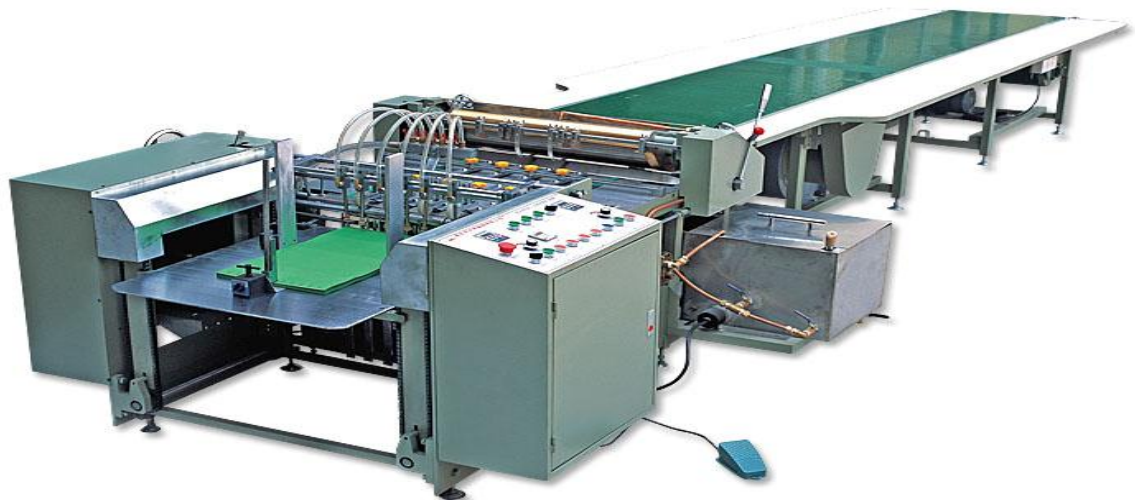

Semi-automatic bookcase envelop machine. Is refer to file box, hard book covers.the pack book hull etc.bookcase envelop machine.

The host adoption vari-resisting to adjust soon, flying to reach the auto last paper gum,setting time arbitrarily to heat automatically,automatic control temperature etc.the forerunner's electronics electric appliances component,function stability,operation celerity.

Pipelining installs strong dint to absorb breeze device,can avoid paper over the gum behind bent change a type and move, make fixed position accurate,The coda wraps a side the ,with the rear using automaktic edge covering and leveling devices to better guarantee product quality. No bubble,no crimple,raise product quality availably.

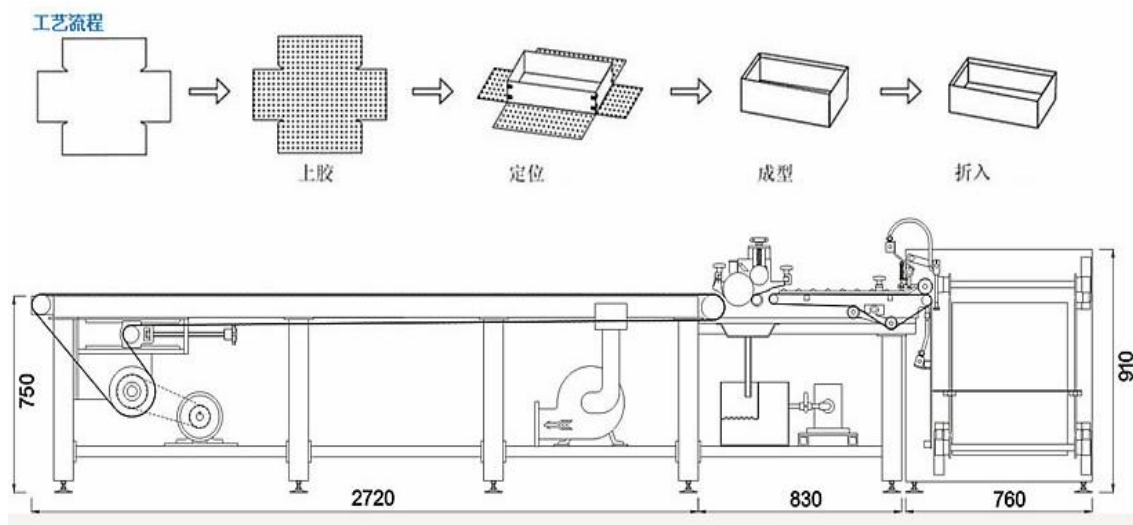

First, welcome to use the KL-650 Automatic Gluing machine which from our company production, before running the machine please reading detailed about the manual, can make you control the usage smoothly in the short date.

#### One、Outline:

KL-650 Automatic Gluing machine is produced to user in Taiwan technical, and our factory especially design the machine for adhibition the packing box, for example point to wine box, smoking box, gift box, belt box, skinny shoe box, curative box, lighter box, tea box and so on.. This machine glue uniformity and operate simple, the recycle glue container have install the indirect heating and the temperature control system insure the coherence of the glue, vacuum absorbing transmission work-set can make absorb firm and go ahead with the level paper. Disposal the timing motor to adjust the speed of the glue. Glue equipment and transmission

equipment controlled by the separately motor, at the same time equip with the durable erosion roller and vessel, the machine shell is beautiful, operation is safe and simple that is the first machine for printing and packing in today.

#### Two、 Usage scope:

This machine is suitable for the stick of the different packing boxes.

#### Three、 Main technical parameter:

Case size:	W80-600mm
Production speed:	7-40units/min
Sheet thickness:	80-200g
Cardboard thickness:	1-4mm
Heater required:	380V / 3HP
Power:	4Kw
Dimension:	1650X1100X6350 mm
Weight:	1200 Kg

#### Four、 structure outline:

This machine mainly constituted by the fuselage of airplane, the ascend gum device and the transport device, the glue to add mat, equip circularly, pipe pump, limitless adjust transducer motor, electric appliance

control cabinet and the blower.

- 1, Install: Prop up each parts of the whole machine.
- 2, Glue device: Will stick to face the paper to glue up the glue.
- 3, The transport device: Transport the box with papers after glue match headway.
- 4, The glue heat device: glue heat be sent to the glue roller by the pipe pump circularly to use.
- 5, The absorb breeze device: Make the have stick face paper to absorb up transmission belt and to move ahead.
- 6, Limitless adjustable electrical engineering: Arouse up the gum and transport that the dynamic motive source of the machine spread.
- 7, The electric appliance control cabinet: Control the whole machine spread and the heat.

Five、Install and debugging:

- 1, Machine must install on the neat cement ground, and adjust the bolt of the ground feet to make the machine as far as possible level.
- 2, Link all power supply, switch on power source.
- 3, Adjust the distance for glue machine 、 lead roller 、 vessel roller 、 including the belt conveyer loose tight moderation.
- 4, Open limitless adjustment electrical engineering, first for empty machine to work, treat normal fall into the glue between of the two screw,

let it revolve even.

5, See to the indoor temperature circumstance, general the glue temperature control in **70°C**.

#### Six、 Operation:

1, After adjust complete, put into the paper one by one, the purpose is to make paper stick on the steel-roller.

2, When the paper stick in the glue and absorb on the transmission belt, operator can put the box in the appropriate position to operation stick the paper.

#### Seven、 Support and maintain:

1, Adjustment the loose or tight should suitable between the glue roller with the steel roller in order to prevent influence even of the glue and the service life of gum.

2, After shut down machine should to clean for the glue up steel roller, in order to prevent the glue concretion difficult to clean so will damage the glue roller or steel glue.

3, Each the spread piece、 bearings and the decelerate machine should to add the lubricant periodically.

#### Eight、 Safe regulation:

- 1, Before use the machine please detailed reading the introduction book, according the right request usage and support the machine.
- 2, Should to use the electricity safety, if the electric wire damage, should replace in time.
- 3, When operate, all the protect cover can not open, behind of the machine forbid the person stand.
- 4, Check each parts periodically, if found the excrescent voice should check to fix in time to insure the normal operation of the machine.
- 5, Switch on strictly forbid to the hand stretch into the glue roller and the steel roller, in order to prevent to hurt.
- 6, Can't pare off the rubber roller and the steel roller with the sharp knife, forbid to damage neat of the roller.
- 7, Before leaving the machine, must clean each roller after turn off the power supply.

(This machine technique improve increasingly, the data change won't notice again, if not clear, please contact with us.)