

KL-450 CASE MAKING MACHINE

ZHEJIANG KANGLI PLASTIC-COATING MACHINE CO.

The Chinese supplier and manufacturer of Casemaker, Gluing Laminator Machine, Box making machine,-Cardboard Slotting Machine, Creasing & Cutting Machine, Surface Binding Machine. We also manufacture various PVC packages, rosewood and redwood boxes, and cartons.

Address: 104 National Highway, Side of PingYang Toll Station, Zhejiang, China

Telephone: 0086-13695835483 0086 -577-63016333

Fax: 0086-577-63017420

E-mail: admin@kanglycn-packing.com

Website: <http://www.kanglycn-packing.com>



飞达头 (Feeder)



上胶部 (Gluing Part)



纸板送料台 (Cardboard Feeding Table)



折边部 (Folding Part)

FUNCTION:

This machine adopts resultant type automatic feeding system for paper and gluing, Many pieces cardboard automatic feeding, location and four side wrap and press. There are Features of accurate ,quick position, beautiful finished products. it is used to make perfect book covers, calendars, hanging calendars, files etc.

FEATURE:

Adopting capacity touch-screen show and operate,can insure people operating machine more convenience and straight.

Feeding paper part,there is an automatic machine-stop device when paper overlaps and winds, it is better to remove the overlap and wind paper in time and keep the machine running normally.

Paper gluing part,there is an automatic location device, it is better for paper location correction.

The cardboard feeding table is controlled by linear guide line and stepping motor, its location is correct and quick

Paper feeding and positioning system adopt imported high-precise photoelectric control device to make the paper and cardboard location more accurate and stable.

Cardboard with paper, there is location device, insure cardboard and paper location is accurate.

In the cardboard feeding table, the machine can automatically stop when lack of paper to reduce the paper waste.

The automatic four-edge folding machine adopts special automatic angle-repair,edge-repair to ensure the qualification of finished products.

The craft line:

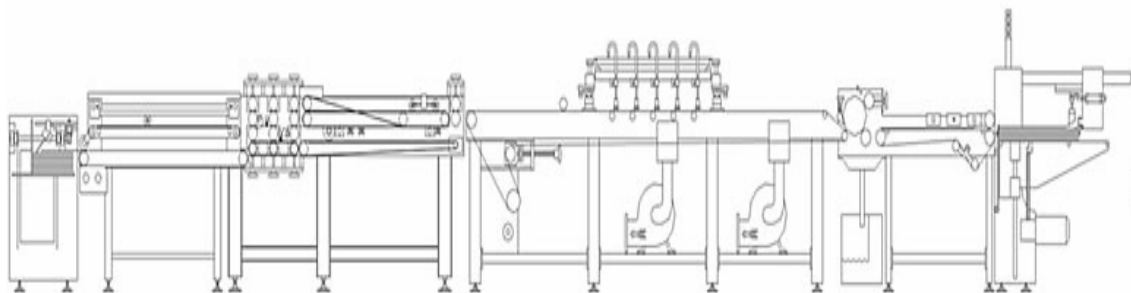
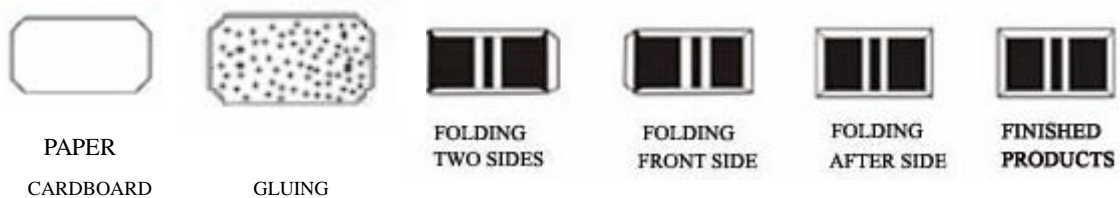

1 SUMMARIZE

KL450 Automatic Covering Machine is composed of paper feeding, gluing, cardboard localization and four side folding parts, In which four folding part complete by an independent KL450 automatic folding machine. The feeder uses entire air operated boosts type to feeding the paper, controlled by PLC, the operation is simple, and the paper transport platform have the paper error correct function; The gluing part design to be reasonable, daub glue water uniformity, the new design copper shaving knife in concert with the rubber roll closer, durable; Underneath the conveyor belt has the high efficiency suction fan, adsorbs the paper steady transportation, the surface paper uses the import photoelectricity switch localization, the cardboard transportation uses the linear guide rail, the servo electrical machinery transmission; Four side folding have the trimming edge and angle function, automatic four side folding, the material receives platform have the automatic elevation function.

2 MAIN SPECIFICATIONS

NO.	ITEM NAME	SPECIFICATIONS	UNIT
1	Paper width WP	100-480	mm
2	Paper thickness	80-200	gsm
3	Cardboard thickness	1-5	mm
4	Product speed	<25	sheet/min
5	Final product Max. dimension LC x WC	800x450	mm
6	Final product Min. dimension LC x WC (one piece)	180x110	mm
7	Cardboard Min. dimension WB1	10	mm
8	Cardboard Min. dimension WB2	30	mm
9	Cardboard most piece	5	piece
10	Cardboard localization precision	±0.50	mm

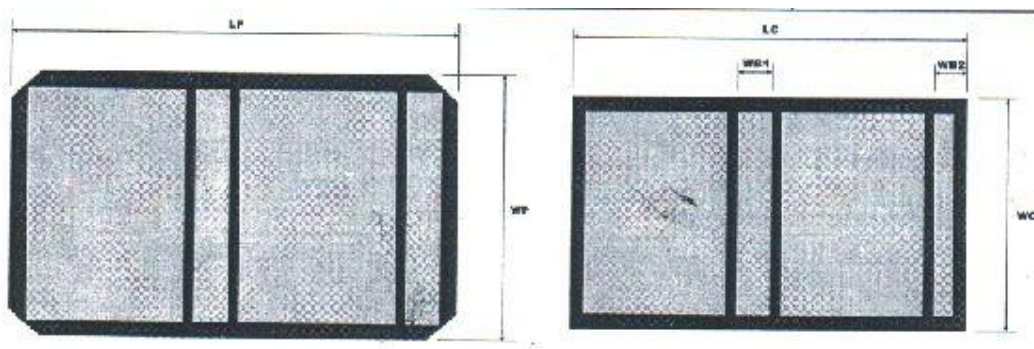

(Picture 1)

3.CONTROL PANEL ICON FUNCTION

The machine running button is same with the computer

Cardboard push button, press one time pushes the cardboard once

Crash stop button, press one time the machine will stop urgently

Pause button is same with the computer

Counter

Power button switch

Thermometer, control the glue water temperature

Computer power switch

Electrical machinery power switch

Glue pot heat up switch

Edge trimming switch

Angle trimming switch

Conveyer belt suction fan switch

Paper transport platform suction fan switch

Cardboard feeding platform vacuum pump switch

Electrical machinery and power switch

Indication of speed

3 MACHINE VARIOUS PART OF EXPLANATIONS

1. Feeder(see also)

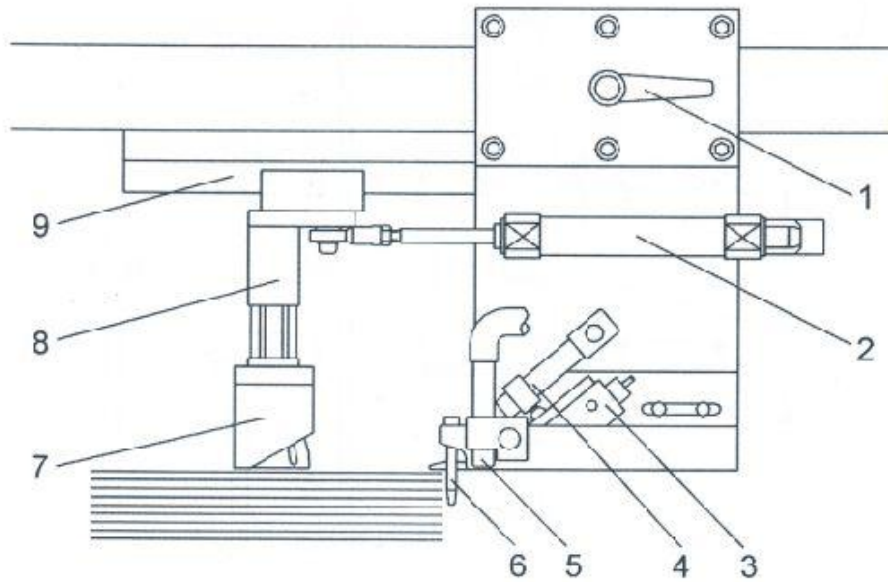

(Picture 2)

- | | | |
|-------------------------|------------------------|---------------------|
| 1. Adjust handle | 2. Push ahead cylinder | 3. Sensitive switch |
| 4. Paper press cylinder | 5. Huff | 6. Paper block rule |
| 7. Suction nozzle | 8. Push down cylinder | 9. Liner guide rail |

2. Paper transport platform(see also)

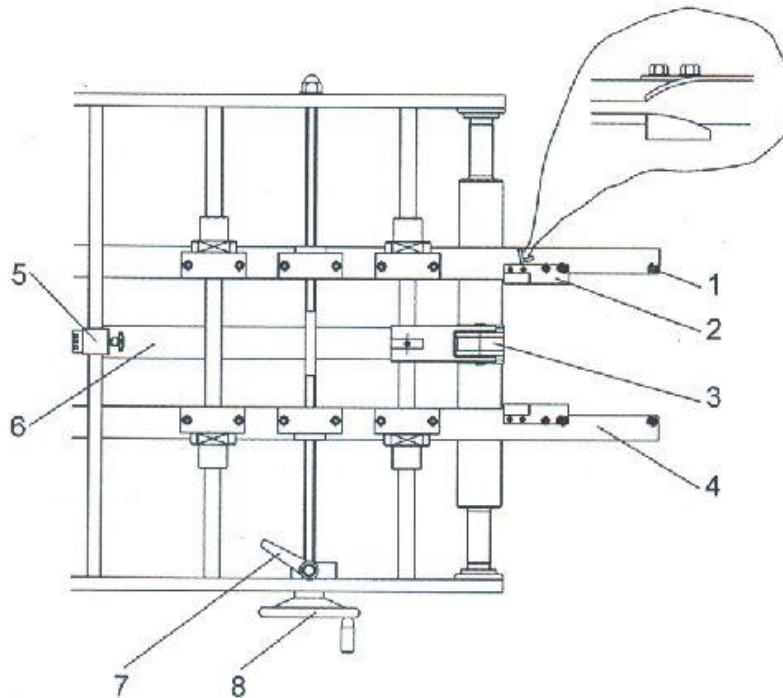

(Picture 3)

1. Paper block rule
2. Paper guide trough
3. Paper transport pinch wheel
4. Paper transport runner
5. Photoelectricity switch
6. Paper conveyor belt
7. Locking handle
8. Hand wheel

- 1) Paper transport runner is adjust by the handwheel, at first loosens the lock screw, then tightening up the screw, guaranteed the machine does not deviation when running, therefore request the paper width is consistent, sometimes the paper cannot through please inspect the paper width is whether consistent or not, or inspection runner width "W" whether match with paper width "WP".
- 2) Paper transport runner width "W" should to match with the paper width "WP" equality, if there's some deviation when feeding the paper, after the process runner that will be corrected, so guaranteed the after glued paper has not produced to deviation on the conveyor belt.

3. Gluing part

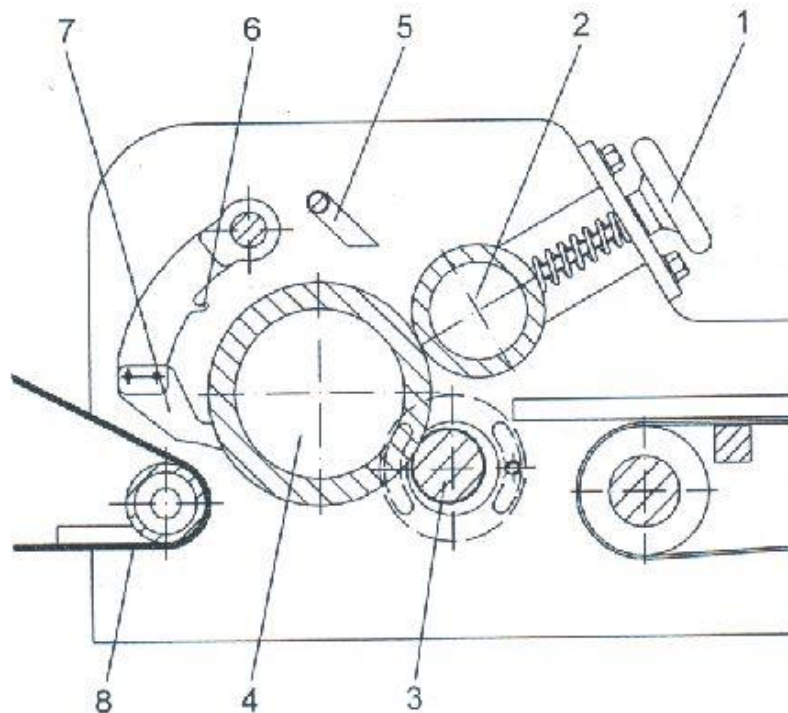

(Picture 4)

1. Adjust handwheel
2. Gluewater adjust roller
3. Whorl roller
4. Gluing roller
5. Gluewater extrude pipe
6. Spring lamination
7. Copper shaving knife
8. Conveyor belt

- 1) The copper shaving knife should coordinate closely with gluing roll, the copper shaving knife radian should tally with gluing roll, this copper shaving knife design in the use can coordination with gluing roll very good, sometimes the copper shaving knife place has the drop glue phenomenon, should clean the copper shaving knife, and keep clean; if the copper shaving knife is not sharp, please mill it promptly.
- 2) Inspect the copper shaving knife elasticity before use, if it does not have the

elasticity should to process or replace the spring promptly, otherwise paper will appear the shaving knife trace after sizing.

- 3) Adjust the handwheel to regulate thickness of glue water and keep spreads evenly.
- 4) Adjust eccentricity wheel could adjust the spacing between whorl roller with sizing roller, if the paper thick, the spacing should move larger (should to clockwise adjustment); when the paper thin, the spacing should move smaller (should to counter clockwise adjustment).When adjusts the eccentricity wheel, should control each side wheel, if the spacing is dissimilar, the after spread paper to be able to appear the crooked phenomenon.

4. Glue pot usage

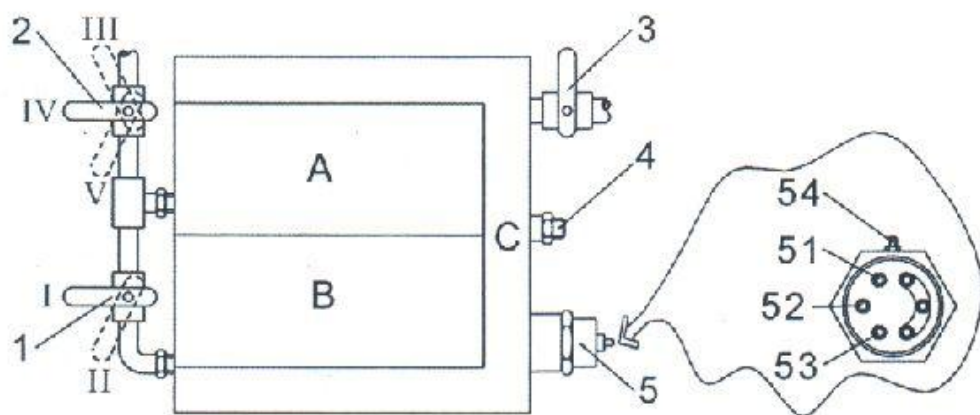

(Picture 5)

- | | | |
|----------------------------------|--------------------------|-------------------|
| 1. Water pour valve | 2. Glue water pour valve | 3. Draw off valve |
| 4. Resistance thermometer sensor | 5. Heat pipe | 51. Terminal (1) |
| 52. Terminal (2) | 53. Terminal (3) | 54. Terminal (4) |

The glue pot divides into three parts: The A trough for the glue water which uses, the B trough is presently the preheating glue water, the C trough is water.

- a) When the water which in the C trough is dirty, should open draw off valve, drain the dirty water and change the clean water promptly (attention: When turns on the water should close the heat pipe).
- b) When the valve 1 is in the position of (I), and the valve 2 is in the position of (III), the glue pump pulls out is the water.
- c) When the valve 1 is in the position of (II), and the valve 2 is in the position of (IV), the glue pump pulls out is the glue water.
- d) When the valve 1 is in the position of (I), and the valve 2 is in the position of (V), pull the water from A trough into C trough.
- e) Heat pipe connection: The Terminal 1, Terminal 2 and Terminal 3 may connect with other three hot wires willfully, and have not order, the other three series connected terminal needn't wiring; The Terminal 4 connect with the zero curve.

5 MACHINE PART NAME AND FUNCTION EXPLANATION

1. Adjust handle: adjust the feeder position according to the paper length.
2. Paper transport platform: Stack printing paper platform
3. Back press paper
4. Suction nozzle
5. Huff nozzle
6. Paper block rule
7. Range switch
8. Front block board
9. Signal lamp: failure signal light, and has the buzzer
10. Paper press wheel
11. Paper press spring
12. Paper guider
13. Photo electricity I: used to test if there's paper on the transport platform
14. Adjust hand wheel: adjust the paper block rule and paper guider according to the paper width
15. Glue pump
16. Adjust hand wheel: adjust the glue water
17. Glue water adjust roller
18. Sizing roller
19. Paper press roller: adjust it according to the paper thickness
20. Glue water extrude pipe
21. Shaving knife
22. Glue water trough
23. Glue water pot
24. Photoelectricity II: used for emergency pause when the paper to be involved in the roll
25. Photoelectricity III: conveyor belt emergency pause
26. Photoelectricity IV: Locates the paper position to control the conveyor belt and the cardboard transport platform movement.
27. Guide rail
28. Baffle: adjust according to the paper width
29. Suction nozzle: adsorb cardboard
30. Suction nozzle seat
31. Paper pusher
32. Cylinder
33. Adjust hand wheel
34. Prepressing roller
35. Fan: guarantee the paper feeding placidity
36. Conveyor belt
37. Adjust hand wheel: used to adjust the conveyor belt
38. Transmission motor: import servo motor

(See also picture 6)

6 GLUE POT (23) USAGES

1. C trough must infuse the clear water to 90% of the capability, pay attention adds water frequently when using, if the trough is empty, the electricity heat pipe will be burn out.
2. The glue water should infuse into the A barrel first, when dissolves completely moves in into B barrel, if put undissolved glue water into the B barrel, that will cause the glue pump (15) unable to revolve.
3. If the machine doesn't running, and there's enough time to dissolve the glue water, could put the glue water in the B trough directly.
4. When the glue water which in the B trough is too viscosity, should to rotate the Tee valve to water enter glue direction, two valves rotate to open, after infuse the water, turn the Tee valve returns back.

7 MACHINE USAGE

1. Turn on the control panel electric heating power supply, heating the glue water, make the glue water to dissolve completely, adjust temperature according to the different glue water (between 60-80°C), because the glue water's glutinosity have relations with the temperature, therefore must control the temperature nicety.
2. The usage of heating and fixed time knob, when the knob on heating, it expressed heats up immediately; when on fixed time, it expressed carries on the heating according to the setting time, so need to set the time, when setting for N hour, it means after N hour will start to heat up.
3. Push the glue water adjust roller (17) together with the sizing roller (18).
4. Turn on the sizing roller button, running the rubber roll speed and the glue pump speed which on the control panel, causes the glue pump and the rubber roll starts to revolve, pulls out some warm water to the rubber roll for several seconds to preheating, then turn the Tee valve to glue way, the glue water will draw up on the rubber roll.
5. Adjust the glue water adjust roller (17) to regulate the thickness of the glue water.
6. Regulate the shaving knife (21) according to the paper width.
7. Turn on the fan I and fan II.
8. Regulate adjust handle I as the paper length.
9. Regulate the adjust hand wheel 14 as the paper width, Enable the paper transport platform (2) width suitable to the conveyor belt.
10. Cardboard feeding platform could lay aside seven different specifications of the cardboard simultaneously, the minimum width is 10mm, adjustment the baffle(28) according to the different width of the cardboard, loosen the screw, and electrical control width.
11. Regulate the adjust hand wheel (33) and the paper pusher (31) according to the paper length.

12. Turn on computer power supply on the control panel, the machine starting to run. (About the computer detail operation, please look over the other manual)

8 SHUT DOWN

1. Push the glue water adjust roller (17) together with the sizing roller (18).
2. Turn the Tee valve to water draw up way.
3. Pulls out some warm water to the rubber roll for several minutes to cleanout the roller, then reset glue pump speed and the glue roll speed, shut down glue roll button, at last stop pump water.
4. Separate the glue water adjust roller (17) from the sizing roller (18).
5. After uses period of time, the water which in the C trough will be dirty, it need to open the draining water valve to eliminate the dirty water, and change the clean water.
6. Shut down the computer switch, the machine will be stop.

9 NOTICE

1. After install the machine, please note watches the control panel power source voltmeter, the fan and the vacuum pump motor revolution direction when connect the power.
2. The glue water must dissolve completely to use, or that will be damage the glue pump (15).
3. Adjust temperature according to the different glue water (between 60-80 °C),because the glue water's glutinosity have relations with the temperature, therefore must control the temperature nicety. .as the glue water temperature elevates slowly, must wait for the glue water to achieve this temperature, and then may carry on the work.
4. When power cut off suddenly, should to transfer the T valve to the water pump direction, regulate the glue pump (15) axle center (counter clockwise) by hand, lets the glue water flow out of the copper pipe, to prevent glue water became hard in the copper pipe and blocks the copper pipe.
5. If the glue water is hard in the copper pipe, and the glue pump transfers motionless, may dismantle the copper pipe clean with water, but do not dismantle glue pump (15), could to burn down the glue pump to causes the glue water dissolution.
6. Paper press roller (19) when replacement paper, needs to adjustment according to paper thickness.
7. Separate glue water adjust roller (17) with sizing roller when the machine stopped, if it is closed for a long time, will be able to cause glue roll and sizing roll aberration, will spread sizing non-uniform.
8. The frequency transducer could not moist or clean with water.
9. When the frequency transducer has exceptionally or touches by mistake may shut down the power source and reopen, then will restores normal work, if has

not restored normally, please consult the frequency transducer manual elimination breakdown.

10 FAILURE REMOVAL

1. Suction two pieces of paper at one time:
 - A. Separates the paper thoroughly, neaten the paper first.
 - B. Press the curl paper evenly.
 - C. Eliminates the static electricity which on the paper.
 - D. May the wind power insufficient
 - E. Underlay the rear part of paper higher.
2. The paper transport not smoothly:
 - A. Check the paper press wheel (10) position is correct or not, if has press the belt.
 - B. Check the paper press spring (11) whether compaction the paper or not.
 - C. The paper transport platform must be clean.
 - D. Paper guider should 0.2-0.5mm more width than paper
3. The paper sizing not smoothly:
 - A. If the paper stuck on sizing roller (18), must to increase space between the paper press roller (19) with sizing roller (18).
 - B. If the paper sizing asymmetry, must to regulate reduces space between the paper press rollers (19) with sizing roller (18).
4. The after glue paper come out not smoothly:
 - A. May the shaving knife have rubdown, need to change.
 - B. May the shaving knife is too sharply, so the paper would lacerate the paper, should to abrade with sand paper.
 - C. Lay down the shaving knife tool depresses the sizing roller (18) before gluing, otherwise the paper (18) would be entangled on the sizing roller, and difficult eliminates.
5. Clear away the paper which entangled on the sizing roller:
 - A. The machine stop automatic, the glue pump and sizing roller will stop when paper entangled on the sizing roller.
 - B. Try to clean up by hand
 - C. Or use blade to lacerate the paper slightly
 - D. If the time is too long, the paper already firmly stuck to the roller, had to use the cleaning rag with the hot water to scratch the paper, until scratched clean completely.
6. The fan suction insufficient:
 - A. At first check the fan, if there's some trouble
 - B. Clean up the underside of the conveyor belt
 - C. Clean the vane of the fan
7. The conveyor belt running deflection, the conveyor belt will leaning toward the tight direction, may rotate the regulating hand wheel (37) to carry on adjustment, if conveyor belt leaning toward to the right, may loosen right side or

tighten left side, but the conveyor belt couldn't too tight, otherwise the joint be able to split, also may not too loose, or it'll be able to racing.

8. The cardboard couldn't feed:

A. The baffle (28) is too tight, so the cardboard couldn't feed smoothly.

B. Whether the cardboard does distorted or warped, must to press it.

C. Whether the cardboard doesn't tidiness and the size is difference

D. The cardboard need to cut in special board slitter better

9. The machine stopped by failure, the signal lamp will shine

A. The paper platform hasn't paper;

B. Make a check if there's paper be entangled on the sizing roller;

C. There's no cardboard on platform or hasn't using suction nozzle switch is turn on;

D. When the feeding cardboard is less than setting, the machine will stop automatically;

E. There's not enough air pressure

11 FOLDING PART NAME AND FUNCTION EXPLANATION

1. Adjust handwheel (left and right each one): Adjusts the pressure of prepressing roller.

2. Prepressing roller: prepressing the paper and cardboard before folding

3. Paper press roller(left and right each one)

4. Conveyor belt

5. Folding belt

6. Terminal strand

7. Adjustment tie bar: adjust the pressure between conveyor belt and folding belt

8. Adjustment handwheel (left and right amount 12 pieces): adjust according to the thickness of paper

9. Planish roller(12 pieces)

10. Hair brush

11. Crispening device

12. Left adjust hangwheel:

13. right adjust hangwheel

14. Front angle trimming cylinder (left and right each one)

15. Back angle trimming cylinder(left and right each one)

16. Photoelectricity switch

17. guide board(left and right each one)

18. Paper pusher

19. Pinch wheel I (left and right each one): If cardboard not smooth, must press and transportation

20. Conveyor belt

21. Paper conveyor belt

22. discharge port belt

23. Pinch roller II: transport the paper more smoothly
 24. Adjust handwheel (left and right each one): adjust according to the thickness of paper
 25. Limit switch: When touches the cardboard, the final product receive platform automatic drop
 26. Final product receive platform
- (See also picture 7)

12 OPERATION FLEW

1. Regulate the hand wheel (1) according to the thickness of paper, so as to prepressing(2) the paper and cardboard with prepressing roller.
2. Regulate the space between paper press roller (3) and conveyor belt(4),make the cardboard feeding smoothly.
3. Regulate the adjustment tie bar (7) as the thickness of the paper, make the space which between conveyor belt(4) with folding belt(5) suitable to cardboard.
4. Adjust the hand wheel (8), make the first layer roller and fourth layer roller space suitable to the thickness of the paper.
5. The way to regulate the roller: put the sample cardboard into the space between the first layer roller and fourth layer roller.
6. Look over the conveyor belt (4),if it is too loose, should to adjust the pinch wheel.
7. Look over the folding belt (4),if it is too loose, at first should to loosen the tightening screw ,then adjust the terminal strand, at last tight the screw.
8. Regulate the left handwheel(11) and right handwheel(12) to adjust the left and right folding belt(5) according to the paper width W.
9. Regulate the handwheel(24) to make the left and right guide board(17) space as the width W of cardboard.
10. Regulate the position of the photoelectricity switch (16) as the length of paper.
11. Regulate the position of the front angle trimming cylinder (14) and back angle trimming cylinder (15) as the length of cardboard.
12. Adjust the photoelectricity switch position which under the paper conveyor belt according to the length of paper.
13. Regulate the position of limit switch (25) according to the length of cardboard.
14. Turn on the power of folding machine and adjust the speed, normally the speed is faster than gluing machine.

13 FAILURE REMOVAL

1. When the paper comes into the folding part and has deviation, should to adjust the position of the folding belt, ensure it in the middle.

2. The paper surface has the corrugation
 - A. Adjust the handwheel(1),make the prepressing roller lower.
 - B. The glutinosity of glue water is insufficient.
 - C. The machine uses quick-drying glue water, so temperature has large affect with glutinosity, to the best of your abilities to install an air condition.
3. The side of the cardboard not tight
 - A. The glutinosity of glue water is insufficient.
 - B. The machine uses quick-drying glue water, so temperature has large affect with glutinosity, to the best of your abilities to install an air condition.
 - C. Regulate the left handwheel(12) and right handwheel (13), reduce the space of them.
 - D. Regulate the tie bar (7) to enlarge the pressure between folding belt and conveyor belt, but the pressure shouldn't too strong, or there's mark on the product.
4. If the final product four angles don't tidiness, should to readjust the front angle trimming cylinder (14) and back angle trimming cylinder (15) position.